

Clean Breeze Wind Park

DRAFT- Wind Turbine Specifications Report

Prepared by: *M.K. Ince and Associates Ltd.*

Prepared for: *Clean Breeze Wind Park LP*

January 23, 2013





M.K. INCE AND ASSOCIATES LTD.
Renewable Energy & Environmental Consulting

www.mkince.ca

11 Cross Street, Dundas, Ontario, L9H 2R3

Tel (905) 628-0077

January 23, 2013

Ingo Stuckmann
WindWorks Power Corp
346 Waverly Street
Ottawa, Ontario
K2P 0W5

Attention: **Dr. Ingo Stuckmann**
Reference: **Clean Breeze Wind Park, Draft Wind Turbine Specifications Report**

Dear Dr. Stuckmann,

We are pleased to present a draft copy of the Wind Turbine Specifications Report for Clean Breeze Wind Park. This report was prepared to meet the requirements of the Renewable Energy Approval regulations, O. Reg. 359/09, Section 13. It will be included as part of the Renewable Energy Approval Application package to be submitted to the Ministry of the Environment for the Clean Breeze Wind Park project.

Please feel free to contact us if you have any questions or concerns.

Sincerely,

M. K. INCE AND ASSOCIATES LTD.

Martin Ince, P. Eng.

Table of Contents

1	INTRODUCTION	1
2	WIND TURBINE SPECIFICATIONS	1
3	QUALIFICATIONS AND LIMITATIONS	2

List of Tables

TABLE 1 REPOWER MM92 SUMMARY	1
TABLE 2 REPOWER MM92 OCTAVE BAND (FOR INFORMATION ONLY).....	2

List of Appendices

Appendix A – Manufacturer Specifications

1 INTRODUCTION

The Clean Breeze Wind Park project is a Class 4 wind facility as defined by *O. Reg. 359/09* and as such is required to provide a Wind Turbine Specification Report. As required by the regulations, this report includes the make, model, name plate capacity, hub height above grade, and rotational speeds. Acoustic emissions data is reported in accordance with CAN/CSA-C61400-11-07, “Wind Turbine Generator Systems – Part 11: Acoustic Noise Measurement Techniques”, including the overall sound power level and uncertainty, octave band sound power levels (linear weighted), and tonality and tonal audibility.

2 WIND TURBINE SPECIFICATIONS

The turbine chosen for Clean Breeze Wind Park is the REpower MM92 turbine. The tables below summarize the required information as per REA regulations. Further information can be found in the appended manufacturer reports. Note that the appended “Repower MM92 Product Description” refers to the 2.05 MW version of the turbine, but the project will use the 2.0 MW version. However, all technical specifications with the exception of total power output and maximum sound power level are the same for both versions. The 2.0 MW turbine has a sound power level lower than that of the 2.05 MW turbine.

Table 1 REpower MM92 Summary

REA Specification	Information	Source
Make	REpower	Technical Description for the Repower MM92 (2 MW, 60 Hz) (See Appendix A)
Model	MM92	
Name Plate Capacity	2.0 MW	
Hub Height above grade	100 m	
Sound Power Level	103.2 dB(A)	
Frequency Spectrum	See Table 2 below	
Rotational Speeds	7.8 – 15 RPM	REpower “REpower MM92 Cold Climate Version Product Description” (See Appendix A)

In the event of a change in turbine model, REA reports will be updated as required, including a description and specifications of the updated turbine model, any additional environmental impacts and updated distances between project infrastructure and surrounding natural heritage, water and other features.

Table 2 REpower MM92 Octave Band (for information only)

		Wind Speed at Height of 10 m (m/s)				
		6	7	8	9	10
Frequency (Hz)	63	81.8	83.3	83.8	83.6	84.6
	125	90.9	91.3	91.2	90.8	89.5
	250	96.4	96.9	96.1	95.7	93.8
	500	97.9	98.7	98.4	98.1	97.3
	1000	96.1	97.1	97.7	98	98.3
	2000	90.6	91.5	92.4	93	95.5
	4000	82.8	83.8	85.1	86.2	91.7
	8000	72.1	73.6	76.4	77.4	80.2
Sum (dBA)		102.4	103.2	103.2	103.2	103.2

3 QUALIFICATIONS AND LIMITATIONS

M.K. Ince and Associates Ltd. (MKI) have prepared this report in accordance with information provided by its Client. The information and analysis contained herein is for the sole benefit of the Client and save for regulatory review purposes may not be relied upon by any other person.

The contents of this report are based upon our understanding of the guidelines and standards which we believe to be current at this time. Changes in guidelines and standards can occur at any time, and such changes could affect the conclusions and recommendations of this report.

While we have referred to and made use of reports and specifications prepared by others, we assume no liability for the accuracy of the information contained within those reports and specifications.

Appendix A

Manufacturer Specifications



Montreal, Aug. 1st, 2012

Object: Technical Description for the REpower MM92 (2 MW, 60 Hz)

Dear Mr.

With regards to the REpower MM92 wind turbine model, find below a summary of the main features:

1. Turbine Type: MM92, 2 MW type, 60 Hz, 100 m hub height;
2. Guaranteed maximum overall sound power level in dBA:

$L_{WA,95\%} = 103,2 \text{ dB(A)}$. Due to typical noise measurement uncertainties, measured values can differ from the values shown in this document in the range of +/- 0,8 dB."

Octave Band Spectra:

		Wind Speed at Height of 10m (m/s)				
		6,0	7,0	8,0	9,0	10,0
Frequency (Hz)	63	81,8	83,3	83,8	83,6	84,6
	125	90,9	91,3	91,2	90,8	89,5
	250	96,4	96,9	96,1	95,7	93,8
	500	97,9	98,7	98,4	98,1	97,3
	1000	96,1	97,1	97,7	98,0	98,3
	2000	90,6	91,5	92,4	93,0	95,5
	4000	82,8	83,8	85,1	86,2	91,7
	8000	72,1	73,6	76,4	77,4	80,2
Sum (dBA)		102,4	103,2	103,2	103,2	103,2

The wind speed at 10 m height is based on a roughness length of 0.05 m. The sound power levels presented per octave band are informative only. The uncertainty on the provided sum levels is not included.

3. The acoustic emission data provided by REpower are determined and reported according to IEC61400-11:2002 +A1:2006. This standard has been adopted without modification as CSA Standard CAN/CSA-C61400-11-07.
4. REpower warrants that there is no tonal audibility $\Delta L_{a,k} > 0 \text{ dB}$ (greater equal $V_{10}=6 \text{ m/s}$).

Sincerely,

Helmut Herold
General Manager
REpower Systems Inc.

REpower Systems Inc.,
1250, Boulevard René-Lévesque Ouest, bureau 3610, Montréal, Québec, Canada, H3B 4W8

REpower MM92
Cold Climate Version
[60Hz/2050 kW]
Product Description

Product Description

REpower Systems SE

Überseering 10

D-22297 Hamburg

Germany

Phone.: +49 - 40 - 5555090 - 0

Fax: +49 - 40 - 5555090 - 3999

www.repower.de

Copyright © 2011 Repower Systems SE

All rights reserved.

Disclaimer (Canada)

Protection Notice DIN ISO 16016 : The reproduction, distribution and use of this document as well as the communication of its contents to others without explicit authorization in writing by REpower Systems SE is strictly prohibited. Offenders will be held liable for the payment of damages. Furthermore, all rights reserved in the event of the grant of a patent or industrial design.

Please ensure to use the latest versions of the applicable specifications. Images do not necessarily reflect the exact scope of supply, specifications, size or materials and are subject to technical alterations at any time. Please note that this document may not correspond with project-specific requirements.

Possible work procedures described in this product description comply with German, and REpower's, safety provisions and regulations. The national laws of other countries may provide for additional safety specifications.

It is essential that all safety measures, both project and country-specific, be strictly complied with. It is the duty of each customer to inform itself, implement and comply with these measures.

The applicability and validity of relevant legal and/or contractual provisions, technical guidelines, DIN standards and other comparable regulations are not excluded by the content or examples contained in this product description. Moreover, such contractual provisions and regulations shall continue to apply without any limitation.

All information contained in this product description is subject to change at any time without notice to, or approval by, the customer. REpower Systems SE and/or its affiliates assume no liability for any errors or omissions in the content of this product description. Legal claims against REpower Systems SE and/or its affiliates based on damage or injury caused by the use or non-use of the information included herein or the use of erroneous or incomplete information are excluded.

Although REpower Systems SE strives to provide information which is accurate and makes this information available to customers in good faith, no representation or warranty is made or guarantee given as to its accuracy or completeness. The sole applicable warranties in respect of the products described herein shall be those provided in a contract executed by an authorized representative of REpower Systems SE. EXCEPT AS PROVIDED IN SUCH EXECUTED CONTRACT, REPOWER MAKES NO WARRANTIES, EXPRESS OR IMPLIED, AS TO THE PRODUCT SPECIFICATIONS, PRODUCT DESCRIPTIONS OR THE PRODUCTS HEREIN DESCRIBED. REPOWER EXPRESSLY DISCLAIMS ALL IMPLIED WARRANTIES, INCLUDING THE IMPLIED WARRANTIES OF MERCHANTABILITY, FITNESS FOR A PARTICULAR PURPOSE, TITLE AND NONINFRINGEMENT.

All brands, trade-marks or product names mentioned in this document are the exclusive property of their respective owners.

Product Description

REpower Systems SE

Überseering 10

22297 Hamburg

Tel.: +49 - 40 - 5555090 - 0

Fax: +49 - 40 - 5555090 - 3999

www.repower.de

Copyright © 2011 Repower Systems SE

All rights reserved.

Disclaimer (US)

The reproduction, distribution and utilization of this document as well as the disclosure of its contents to others without explicit authorization in writing from REpower Systems SE are strictly prohibited. Offenders will be held liable for the payment of damages. No license, express or implied, to any intellectual or industrial property rights is granted by these product descriptions or specifications. All intellectual and other property rights are reserved, including but not limited to industrial property rights, copyrights, trademarks, trade secrets, trade dress, or the grant of a patent, utility model, or design.

Each customer should verify that this document is the most current version of the particular product description or specification. Images contained within these product descriptions or specifications do not necessarily reflect the particular products purchased by the customer. Moreover, subject to the particular terms of any binding written contract between REpower Systems SE and the customer, the products covered by these product descriptions or specifications are subject to technical alterations at any time without notice. Please be aware that these product descriptions or specifications are for particular products and do not necessarily correspond to particular project-specific requirements.

These product descriptions and specifications comply with applicable mandatory requirements of IEC 61400, the National Electrical Code (NEC), Underwriters Laboratory (UL), and the applicable mandatory standards of the federal Occupational and Health Administration (OSHA), as well as applicable mandatory Deutsches Institut für Normung (DIN) standards to the extent they are not inconsistent with the above applicable mandatory IEC 61400, NEC, UL and OSHA standards. Customer is solely responsible for identification of and compliance with all other applicable federal, state, local, or project-specific requirements.

Subject to the particular terms of any binding contract between the customer and REpower Systems SE, REpower Systems SE: (a) reserves the right to change or modify any of the products and their physical or technical specifications without prior notice or approval by the customer or any other person; (b) disclaims all liability for any errors or omissions in the content of this product description or specifications.

EXCEPT AS MAY BE SPECIFICALLY AND EXPRESSLY PROVIDED TO THE CONTRARY IN A BINDING WRITTEN AGREEMENT BETWEEN REPOWER SYSTEMS SE AND CUSTOMER, REPOWER MAKES NO WARRANTIES, EXPRESS OR IMPLIED, AS TO THE PRODUCT SPECIFICATIONS, PRODUCT DESCRIPTIONS OR THE PRODUCTS HEREIN DESCRIBED. REPOWER EXPRESSLY DISCLAIMS ALL IMPLIED WARRANTIES, INCLUDING THE IMPLIED WARRANTIES OF MERCHANTABILITY, FITNESS FOR A PARTICULAR PURPOSE, TITLE AND NONINFRINGEMENT.

All brands or product names mentioned in this document are the property of their respective holders.

Table of Contents

Applicable Documents	6
List of Abbreviations and Units.....	6
List of Figures	8
List of Tables.....	8
1 General Information	9
1.1 Design Key Features.....	10
1.2 View	10
1.3 CCV Improvements	11
2 Mechanical System	12
2.1 Rotor.....	12
2.1.1 Rotor Blades	12
2.1.2 Blade Colors and Reflectivity	13
2.1.3 Pitch System	13
2.2 Nacelle.....	14
2.2.1 Yaw System	14
2.2.2 Suspension Concept.....	15
2.2.3 Gearbox	15
2.3 Tower.....	16
2.4 Deck crane	16
2.5 Corrosion Protection	16
3 Electrical System	17
3.1 Principle of Operation.....	17
3.2 Technical Data Low Voltage Side WEC.....	18
3.2.1 Standard Configuration WEC.....	18
3.2.2 Grid Protection Settings Standard WEC	19
3.3 Main Components	20
3.3.1 Generator	20

3.3.2	Converter	21
3.3.3	External Transformer System	21
3.4	House Load	21
3.5	Requirements and Standards	22
4	Safety Concept	23
4.1	General Safety	23
4.2	Safety Chain	24
4.3	Brake System	24
4.4	Safety Equipment	25
4.5	Lightning Protection	25
4.6	Fire Safety	25
5	Wind Turbine Control	26
5.1	Control System	26
5.2	Cut-In / Cut-Out strategy	26
5.3	Measures in case of ice accretion	27
5.3.1	Ice Detection	27
5.3.2	Turbine behaviour in case of ice detection.....	27
6	Masses and Dimensions	28
6.1	Weights	28
6.2	Dimensions	28

Applicable Documents

The documents referred to in the table below are included for information only. Reference to them in this product description does not make them part of any contract between REpower and the customer or any person.

Title	Document no.
Datasheet External Transformer System [MM/60Hz/CCV/CAN]	V-2.6-EL.TR.02-B-*-EN
Datasheet External Transformer System [MM/60Hz/USA]	V-2.6-EL.TR.01-B-*-EN
Fire Safety REpower MD/MM	SD-0.0-ES.EI-4-*-EN
General Information Lightning Protection, Earthing and potential equalization [MM]	GI-2.5-EC.LP.01-A-*-EN
Standard Conditions Of Use REpower MM92 Cold Climate Version [60Hz/2050kW]	SD-2.12-WT.SC.01-A-*-EN
Standard Grid Conditions [MM/60Hz]	SD-2.6-EC.GR.01-A-*-EN

* If the products referred to in the table above are to be included within the project, the relevant product descriptions in their current version shall be inserted in the contract.

List of Abbreviations and Units

Abbreviation/Unit	Description
ETS	External Transformer System
f_N	Nominal frequency
GL	Germanischer Lloyd
GRP	Glass-fibre reinforced plastic
HV	High voltage (nominal grid voltage ≥ 60 kV)
IEC	International Electrotechnical Commission
IGBT	Insulated Gate Bipolar Transistor
I_N	Nominal current
LV	Low voltage (nominal grid voltage ≤ 1 kV)
MV	Medium voltage (nominal grid voltage > 1 kV and < 60 kV)
n	Rated generator speed
NEC	National Electrical Code
P_G	Nominal power generator

Product Description

P_N	Nominal power WEC (nominal active power)
PPE	Personal Protective Equipment
P_T	Nominal power transformer
RAL	German institute for Quality Assurance and Certification e.V.
SCADA	Supervisory Control and Data Acquisition
U	Voltage
U_C	Declared high voltage (supply voltage)
UL	Underwriters Laboratories
U_N	Nominal voltage
WEC	Wind Energy Converter



List of Figures

Figure 1: Outline of REpower MM92 CCV WEC with components	10
Figure 2: Extended Frequency Range of REpower MM92 CCV	18

List of Tables

Table 1: REpower MM92 CCV WEC main components.....	11
Table 2: Technical Data Rotor.....	12
Table 3: Technical Data Rotor Blades	13
Table 4: Technical Data Pitch System.....	13
Table 5: Technical Data Yaw System.....	14
Table 6: Technical Data Gearbox	15
Table 7: Technical Data Towers	16
Table 8: REpower MM92 CCV standard configuration at low voltage side of the WEC	18
Table 9: Standard grid protection settings at low voltage side of the WEC	19
Table 10: Technical data generator	20
Table 11: Technical data converter	21
Table 12: Standards	22
Table 13: General Data Control System.....	26
Table 14: Technical Data Cut-In / Cut-Out Strategy	26
Table 15: Weights.....	28
Table 16: Dimensions Blade.....	28
Table 17: Dimensions Hub	28
Table 18: Dimensions Nacelle	28
Table 19: Dimensions Drive Train	28

1 General Information

The *REpower MM92 Cold Climate Version (CCV)* is a variable speed wind energy converter (WEC) with a rated power of 2,050 kW and a rotor diameter of 92.5 m with electrical single-blade pitching system. Operational experience with more than 2.000 turbines of the *REpower MM series (MM70, MM82 and MM92)* has been incorporated in the development of the *REpower MM92 CCV*. The *REpower MM92 CCV* has been developed on the basis of the qualities of the MM series and in particular with regard to ease of maintenance, sturdy construction, generous and conservative design of the components, construction of the load-bearing structures to match the power flux and environmental compatibility.

The MM92 CCV has been optimised for operation at IEC II wind class sites (for available certifications, please refer to the document entitled “Standard Conditions of Use”).

Please understand that the safe and adequate operation of a WEC requires specialized skill, knowledge and training. REpower assumes that each customer and the customer's employees, contractors and subcontractors as well as any other user, have the requisite specialized skill, knowledge and training to safely and adequately evaluate these product specifications and to properly operate the products herein described. REpower further assumes that each customer for itself, and its employees, contractors and subcontractors as well as any other user allow only well-trained individuals on the wind farm, as well as near or within the WECs. Visitors should be appropriately warned and monitored, especially in inclement weather or periods where ice may accumulate and drop from blades. No person should enter the tower or any part of the rotor or nacelle who does not have a need to assume a position within the WEC and does not possess the appropriate training and skill set to be in proximity to or perform work on, near or within a WEC. Inappropriate operation of a WEC, or untrained or undertrained individuals performing any activity on, near or within a WEC, or any type of horseplay on, near or within a WEC, may result in property damage, personal injury or death. The customer assumes the risk and responsibility for ensuring that persons allowed on, near or within any WEC possesses the appropriate skill, training and knowledge to perform whatever role brings them near within or on the WEC. REpower strongly encourages its customers to implement and enforce strict security protocols and measures to keep any individual away from WEC, other than adequately trained professionals employed by and under the supervision of the customer.

1.1 Design Key Features

Following the predecessor turbines *REpower MD70/77* and *MM70/82/92*, the *REpower MM92* CCV mainly comprises the same design key features. Changes were made only where necessary to adapt the WEC to cold climate conditions (see chapter 1.3). Therefore the general design key features of the *MM92* CCV are as follows:

- Yield-improved variable speed generator and converter system
- Fail-safe pitch system with separate control and regulation systems for each rotor blade
- 3-point suspension of mechanical drive train
- Tilted-Cone concept and pre-bent stiff rotor blades for weight balance and load transfer
- Reliable gearbox concept
- Ease of maintenance due to the spacious nacelle design

1.2 View

The following outline shows the side view of the *REpower MM92* CCV nacelle with the main components and their location.

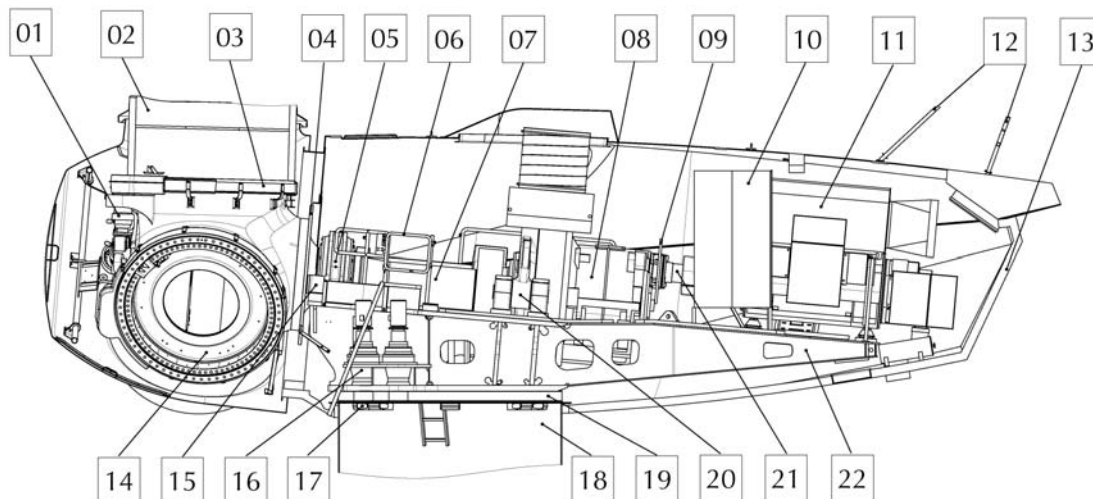

Figure 1: Outline of *REpower MM92* CCV WEC with components

01	Rotor blade pitch system	12	Weather mast
02	Rotor blade	13	Nacelle enclosure
03	Rotor blade bearing	14	Rotor hub
04	Rotor locking disc	15	Rotor locking bolts
05	Rotor bearing	16	Azimuth drive
06	Rotor safety door	17	Azimuth brake
07	Rotor shaft	18	Tubular tower
08	Gearbox	19	Azimuth bearing
09	Rotor holding brake	20	Torque bearing
10	Top box	21	Coupling
11	Generator	22	Machine carrier

Table 1: REpower MM92 CCV WEC main components

1.3 CCV Improvements

To enable the WEC to be installed and operated under cold climate conditions, the MM92 CCV is modified in certain relevant parts and components:

- Low-temperature grease, e.g. for rotor bearing
- Low-temperature hydraulic oil, e.g. for yaw brakes
- Low-temperature lubrication system, e.g. for blade bearing
- Low-temperatures materials, e.g. for blade pitch gearbox and deck crane
- Improved and/or additional heating elements, e.g. for top box, generator and gearbox oil system
- Modified cabinet for top box and base box
- WEC control via laptop interface at top box and base box
- Ultrasonic anemometer for measurement of wind direction and speed
- Low-temperature steel at the door frame and partially increased steel thickness for the tower
- Liquid-cooled converter
- Intelligent heating process to accelerate and secure the re-start of the WEC after a shutdown at low temperatures

The environmental conditions are described in the document "Standard Conditions of Use".

2 Mechanical System

2.1 Rotor

The rotor consists of three rotor blades that are flange-mounted on the cast hub via a blade bearing. The rotor blades can thus be adjusted along their longitudinal axis via the pitch drives. In order to provide continued operation of the pitch system in the event of grid loss or WEC malfunction, each blade has its own independent power supply system using a storage battery set and controller.

In the partial load range, i.e. when the WEC is operated below the rated power, it works at a constant blade pitch and variable speed to exploit optimal rotor aerodynamics. Within the nominal load area, i.e. when the WEC has reached its maximum rotor speed, it operates with a constant nominal torque which is given by the generator. Changes of the wind speed are controlled by the pitch system.

Technical Data Rotor	
Rotor diameter:	92.5 m
Swept area:	6,720 m ²
Speed range:	7.8 to 15.0 (+12,5 %) rpm
Maximum tip speed:	approx. 72.6 m/s
Rotor axis inclination:	5 °
Rotor cone angle:	3.5 °
Direction of rotation:	clockwise
Rotor position:	up-wind

Table 2: Technical Data Rotor

2.1.1 Rotor Blades

The blade design for the *REpower MM92 CCV* comprises a strong structure to face high wind loads but also lightweight construction to minimize the load transmission to the nacelle. This is realized by the use of glass-fiber reinforced plastic (GRP) sandwich construction which provides the needed material properties.

The blades have also been improved for high aerodynamic efficiency and thus to reduce the noise emissions of the WEC. The UV-resistant gelcoat surface of the blades protects the blade structure against penetration of moisture. Also on certain areas like the front-edge of the blade, special protection measures have been taken to avoid erosion. Depending on the type of installed blade, the blade can either be equipped with additional aerodynamic add-ons such as stall barriers and spoilers, but can also have a different shape, which includes these improvements in the blade design itself.

Please note, that REpower Systems SE reserves the right to select and modify, at its sole discretion, the manufacturer or type of blades without consulting the customer.

Technical Data Rotor Blades	
Number of rotor blades:	3
Rotor blade Length:	approx. 45.2 m
Blade material:	Glass-fibre reinforced plastic (GRP)

Table 3: Technical Data Rotor Blades

2.1.2 Blade Colors and Reflectivity

The blades are light grey (RAL 7035) which is a pale standard color. It minimizes reflectivity of a blade efficiently means approx. a reflectivity of 60-80 units while having no influence on the power curve. Furthermore, the blades can be colored with different red markings, which are available as an option.

2.1.3 Pitch System

As described in chapter 2.1, the blades are flange-mounted on the hub via a blade bearing so that they can rotate along their longitudinal axis. The rotation of the blades is performed by pitch drives which are individually attached to each blade and feature individual controller systems. In order to synchronise the individual blade adjustments, an additional synchronisation controller is used. The safe operation of the turbine in event of grid loss or WEC malfunction is ensured by independent uninterrupted power supplies for each pitch drive.

Technical Data Pitch System	
Principle:	electrical-drive, single blade pitch
Power control:	pitch and rotor speed control
Pitch drives:	synchronised DC motors with battery buffer
Maximum blade angle:	91 °
Pitch rate at safety shut-down:	approx. 6-7 °/s

Table 4: Technical Data Pitch System

2.2 Nacelle

To meet today's demands on an innovative WEC, the cabin has been designed by a renowned industrial design firm. The result is an aerodynamic design which has been generously dimensioned to create sufficient conditions for service and maintenance. Maintenance work can be carried out with the nacelle closed, although it is also possible to open the nacelle for a replacement of bigger components.

The nacelle is accessible from the tower via a hatch in the base frame. A maintenance platform has also been installed to ensure that the components below the base frame can also be accessed as easily as possible.

All components, such as the yaw system or the hydraulics, can be operated from the control system in the nacelle. An emergency stop button has been installed for safety reasons. Furthermore, all moving parts within the nacelle are covered to minimise the risk of injuries.

For the housing material, glass-fiber reinforced plastic (GRP) was chosen, as it offers reliable protection and is also very light. Like the blades, the nacelle is also coloured light grey (RAL 7035).

2.2.1 Yaw System

The nacelle is connected to the tower via a contact bearing. Yawing of the nacelle is achieved by means of electrical yaw drives. Hydraulic brake calipers keep the nacelle in the wind direction and keep the yaw drives substantially free of loads which might occur from inflow angles in horizontal or vertical axis. The brakes are also active in a non energized state.

An electronic wind direction sensor with corresponding software controls the switch-on times and direction of rotation of the motors. It also ensures an automatic cable untwist if the nacelle changes its position several times in one direction as a result of changing wind conditions. While the WEC is yawing the brakes are released. Once it has been adjusted towards the wind, the brakes are activated and keep the position of the WEC.

Technical Data Yaw system	
Principle:	electrical geared drives, hydraulic yaw brakes
yaw rate:	approx. 0.5 °/s
bearing:	contact bearing with external toothing

Table 5: Technical Data Yaw System

2.2.2 Suspension Concept

The drive train is supported at three points immediately above the head flange of the tower, whose conical geometry provides a wide basis to absorb the loads. The fore side suspension is carried out by a generously dimensioned spherical roller bearing. The two other suspension points are the torque arms of the gearbox which are balanced by elastomer bushings. Together with the three point suspension, the “tilted-cone” concept and an inclination of the rotor shaft by approximately 5% provides a load transfer into the tower, along with a significant tolerance of the drive train alignment.

2.2.3 Gearbox

The gearbox is designed as a combined planetary / spur gear. The tothing has been improved with respect to efficiency and noise emission. Elastic bushings are integrated in the torque arm of the gear that rest on the base frame via support pieces. The elastic bearing allows an effective sound and vibration decoupling from the main frame. The gearbox design fulfils partly higher requirements and safety factors than given in the ISO 81400-4 (Issue 2005-10). Furthermore, the gearbox is equipped with an electrical and a mechanical oil pump to ensure sufficient oil flow, even under idling conditions.

The gearbox contains an oil particle counter which detects metalliferous particles in the gearbox oil. This system helps identify abrasion of toothings and bearings at a very early stage and thus help preventing a significant damage of the gearbox by taking counter-measures in time.

Technical Data Gearbox	
Principle:	planetary/helical gear system
Mechanical nominal power at rotor shaft:	2,165 kW
Gear ratio:	$i = 96.0$
Direction of rotation:	clockwise
Axis inclination:	5 °

Table 6: Technical Data Gearbox

2.3 Tower

The tower is designed as a conical tubular steel tower consisting of three to five segments, depending on the hub height as stipulated in the sales contract. Like blades and nacelle it is coloured in light grey (RAL 7035). Each tower features a lockable door which allows access for authorised persons to the tower base. A ladder inside the tower gives access to the nacelle and is equipped with a fall protection system. Depending on the hub height of the tower, there are various numbers of platforms at different heights to allow resting and to provide shelter in case of an emergency. The platforms are equipped with additional safety lights.

The cabinets for the converter are mounted in the tower base on a separate platform. The generator power is transferred to the tower base via shielded bus bars and a power cable system. Control signals for the WEC control system are transmitted via optical glassfiber cables inside the tower to comply with electromagnetic compatibility (EMC) requirements.

Technical Data Towers	
Type:	conical tubular steel tower
Hub heights *:	78.0 – 80.0 m and 98.0 – 100.0 m
Diameter of head flange:	approx. 3.0 m
Diameter of bottom flange:	approx. 4.6 m

*The hub heights depend on the foundation design and extension

Table 7: Technical Data Towers

2.4 Deck crane

The nacelle also features a deck crane, which can be used for maintenance tasks to lift tools or components weighing up to 250 kg. The back of the nacelle features a crane hatch which is secured with a safety gate. The deck crane should not, under any circumstances, be used for lifting persons.

2.5 Corrosion Protection

All parts of the WEC are protected against corrosion and other environmental influences by a special multilayer coating. The coating system complies with requirements of DIN EN ISO 12944.

3 Electrical System

3.1 Principle of Operation

The WEC is equipped with a variable speed generator/converter system. This allows the speed to be adjusted within a range of +/-40% of the synchronous speed (including dynamic range). The combination of variable speed operation and electrical pitch adjusting system helps to provide very good results with regard to energy yield, efficiency, mechanical stressing and power quality. The system avoids surges and peak loads. Operating control provided by the generator allows uniform power export with minimal fluctuation in the partial load range. The WEC can be operated at nearly constant power in the nominal load range. The general ability to generate reactive power also allows targeted management of reactive power in accordance with customer and network operator requirements with the addition of optional products.

The functional principle of REpower's variable speed generator is based upon the concept of the doubly-fed asynchronous generator with a converter which takes advantage of IGBT technology. The system assures continuous power generation with voltage and frequency matched to the grid, regardless of rotor speed. Speed and power are adjusted automatically according to the prevailing wind speed. The WEC operates in the following operating ranges depending on the prevailing wind speed:

- ▶ In the sub-synchronous operating mode (partial load range) the generator feeds 100% electrical power to the grid. In addition, slip power is supplied to the rotor from the converter via the generator's slip rings.
- ▶ In the over-synchronous operating mode (nominal load range), the generator feeds approximately 83% electrical power directly to the grid, which does not have to be fed via the converter. Remaining power (approx. 17%) is fed to the grid from the rotor via the frequency converter.

Amongst the various advantages of this system, are the low loss which assures high overall efficiency, and outstanding availability due to the compact design with a minimal number of components.

3.2 Technical Data Low Voltage Side WEC

3.2.1 Standard Configuration WEC

The REpower **MM92 CCV standard configuration** is described at table 8 and table 9.

Parameter	Value
Nominal active power	$P_N = 2050 \text{ kW}$
Power factor	$\cos \varphi = \sim 1$
Nominal voltage	$U_N = 575 \text{ V}$
Voltage range (at LV terminals) ¹ of the WEC ($\cos \varphi = \sim 1$)	$90\% \leq U_N \leq 110\%$
Nominal frequency	$f_N = 60 \text{ Hz}$
Current ($\cos \varphi = \sim 1$; U_N)	$I = 2058 \text{ A}$
Rated generator speed	$n = 1440 \text{ min}^{-1}$

Table 8: REpower MM92 CCV standard configuration at low voltage side of the WEC

The REpower WEC stays connected to the grid within the frequency and related time limits described in figure 2. During this time the voltage has to be close to nominal voltage. Figure 2 describes *Extended Frequency Range* for active power production.

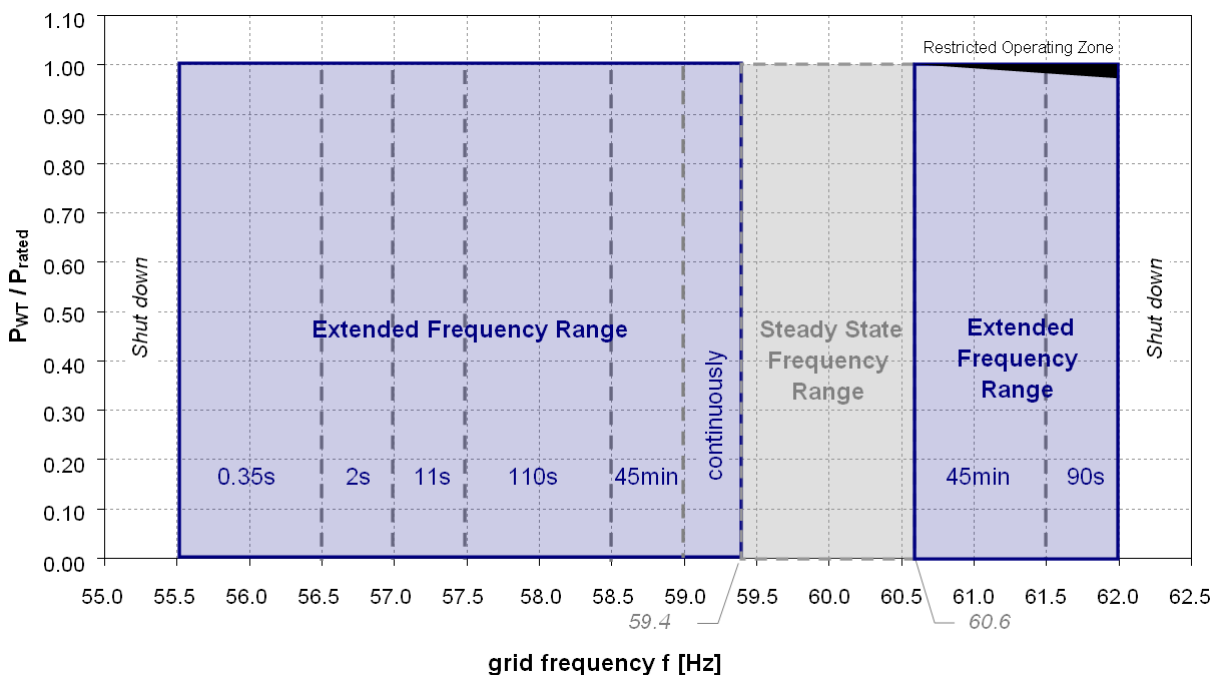

Figure 2: Extended Frequency Range of REpower MM92 CCV

¹The automatic tap changer of the wind farm transformer in the medium-voltage system must assure that line voltage does not drop below nominal voltage for a longer period of time. If the line voltage is below nominal voltage for a longer period of time electrical power production could be reduced.

Within the Restricted Operating Zone in figure 2 an active power reduction down 97.5% of rated active power is possible. The reactive power production may also be affected in the *Extended Frequency Range*.

By adding optional *REpower Grid Products* and/or *REguard Products* electrical capabilities and control functionalities for the single WEC and/or the wind farm can be extended, to fulfil project specific network requirements and manage power plant tasks within the wind farm. ²

3.2.2 Grid Protection Settings Standard WEC

To identify single-phase and three-phase faults the WEC control includes grid monitoring to measure the current and voltage in all phases. The grid monitoring analyses the current, voltage and the fluctuation of the respective values in time to disconnect the generator and converter immediately from the grid if necessary and disconnect the WEC from the grid if any of the events in table 9 occur.

Trigger Event	Trigger Value	Comments
Maximum voltage [U >] (symmetrical/asymmetrical)	$1.1 \cdot U_N$	Setting values shall be defined together with the responsible network operator
Minimum voltage [U <] (symmetrical/asymmetrical)	$0.90 \cdot U_N$	Setting values shall be defined together with the responsible network operator
Maximum frequency [f >]	60.6 Hz	Setting values shall be defined together with the responsible network operator
Minimum frequency [f <]	59.4 Hz	Setting values shall be defined together with the responsible network operator
Phase jump	$\pm 6^\circ$	Undelayed triggering

Table 9: Standard grid protection settings at low voltage side of the WEC

The standard grid protection settings for minimum and maximum voltage can be investigated and adjusted for each specific project depending on the additional *REpower Grid Products*.

The standard grid protection settings for minimum and maximum frequency are adjustable parameters which can be set within the frequency range described at figure 2.

In case of an event in table 9, the WEC will resume to normal operation after grid recovery.

² Corresponding values described in table 8 and table 9 shall change if optional products are chosen.

3.3 Main Components

3.3.1 Generator

Technical Data Generator	
Concept:	Asynchronous doubly-fed generator with rotor power recovery to the grid via the frequency converter. The stator winding is synchronized to the low-voltage side and is connected directly to the grid with a soft cut-in.
Nominal power / speed:	$P_G = \sim 2080 \text{ kW}$ at $n = 1440 \text{ min}^{-1}$ ($\pm 20 \text{ kW}$ depending upon manufacturer)
Speed range:	$n = 770 \text{ to } 1440 \text{ min}^{-1}$ (dynamically up to 1680 min^{-1})
Type:	6-pole, 3-phase asynchronous doubly-fed generator
Model:	IM B3 acc. to DIN IEC 60034 code I IM 1001 acc. to DIN IEC 60034 code II
Size:	500
Protection:	IP 54, enclosure of slip ring IP 23
Cooling:	Surface mounted air-air heat exchanger. External airflow is generated by an external fan. Cooling air is drawn from inside the nacelle.
Sensors:	PT 100 for monitoring bearings PT 100 for monitoring coils Brush wear warning
Miscellaneous:	Covers reduce the risk of contact with rotating parts. The generator housing is earthed for potential compensation. The generator is borne on sound and vibration-decoupling elements on the base frame for reasons of sound insulation and decoupling.

Table 10: Technical data generator

3.3.2 Converter

Technical Data Converter	
Concept:	Frequency converter for asynchronous, double-fed generator with DC intermediate link.
Function:	Control/regulation of active and reactive power. Recovery of rotor power via generator and grid side inverters.
Power semiconductors:	IGBTs
Protection:	IP 54, inductor cabinet: IP 21
Cooling:	Forced air cooling of converter compartment. Liquid cooling system for IGBTs.

Table 11: Technical data converter

3.3.3 External Transformer System

The medium voltage transformer and switchgear are not included in REpower's scope of supply, but have to fulfil the REpower requirements described in the document "Datasheet External Transformer System [MM/60Hz/USA]" for USA and "Datasheet External Transformer System [MM/60Hz/CCV/CAN]" for Canada.

Note: Rated power of transformer must be chosen according to reactive power capability of the WEC. Nominal voltage transformer must be chosen according to the nominal grid voltage of the wind farm.

3.4 House Load

Power required by the WEC in the standby mode is comprised of the individual requirements of the following components:

- ▶ Controls (control computer and converter)
- ▶ Yaw drives
- ▶ Hydraulic pump
- ▶ Heating for gearbox, generator and control cabinets
- ▶ Battery charger
- ▶ Pitch control drive units during self-test and start-up
- ▶ Motor power at shutdown wind speed

Power requirements do not exceed approximately 50 kW (10 minute mean value). House load depends to a great extent upon location. Energy requirements are particularly high when wind speed is lower than cut-in wind speed in combination with the requirement for cold climate specific component heating. Values may fluctuate between coastal and inland locations. An estimate of up to approximately 16000 kWh per year can be assumed at locations with medium wind speeds, although deviations, both upward and downward, are possible. These specifications do not take upstream components into consideration (e.g. transformer and auxiliary equipment, as well as medium and low-voltage cabling).

3.5 Requirements and Standards

Following components (1 to 5), installed in the tower basement of the WEC, comply with the requirements of the respective standards listed at Table 12.

- 1 Converter System
- 2 Basement Box (local control system, communication, measurement)
- 3 Power cable
- 4 Control Cable
- 5 Bus bars

No.	Name	Title
/NR-1/	NFPA 70 (2005 Edit.)	National Electric Code
/NR-2/	NFPA 79 (2007 Edit.)	Electrical Standard for Industrial Machinery
/NR-3/	UL 508 A - Edit. 1 (2001-04)	Standard for Industrial Control Panels
/NR-4/	UL 508 C – Edit. 3 (2002-05)	Standard for Power Conversion Equipment
/NR-5/	UL 857 – Edit. 12 (2001-01)	Standard for busway line
/NR-6/	CSA C22.1	Canadian electrical code Part 1
/NR-7/	CSA C22.2	Canadian electrical code Part 2

Table 12: Standards

It is customer's responsibility to determine whether there are any additional or different requirements imposed by federal, provincial, state or local governments, including special districts if any, in which the project is located.

4 Safety Concept

4.1 General Safety

Like all other REpower WEC the *REpower MM92 CCV* is designed for a high level of operational safety. REpower WECs comply with the mandatory applicable requirements of the U.S. federal safety standards established by OSHA. Since REpower WECs are designed to comply with these mandatory applicable U.S. federal standards, the customer is responsible to determine whether there are any additional or different requirements imposed by federal, provincial, state or local governments, including special districts if any, in which the project is located.

The WEC is equipped with safety devices and sensors that are used for the protection of individuals and the turbine, as well as for its control. This in particular includes:

- ▶ “Fail-safe” aerodynamic brake by the use of independent blade adjustment system
- ▶ Turbine controller independent safety chain
- ▶ Protection against external emission of liquids by the use of labyrinths and collecting trays
- ▶ Coverage of rotating parts in the WEC for the safety of individuals
- ▶ Generous space in the nacelle for service and maintenance
- ▶ Internal access to the hub from the nacelle

4.2 Safety Chain

The safety chain is a hard-wired circuit in which all contacts for triggering an emergency stop are connected in series. If the safety chain is interrupted, the WEC will stop immediately. A reset can only be done when the cause of the interruption has been rectified (except for emergency stops due to grid loss).

The following safety chain contacts can trigger an emergency stop:

- ▶ Emergency stop button on top box (nacelle)
- ▶ Emergency stop button on portable control unit (nacelle)
- ▶ Emergency stop button on the switching cabinet in the tower base
- ▶ Overspeed switchgear for rotor speed
- ▶ Overspeed switchgear for gearbox speed
- ▶ Vibration switch
- ▶ Cam switch (azimuth revolutions counter)
- ▶ Service key switch on the top box
- ▶ Hardware contact on the system management computer

4.3 Brake System

The brake system consists of the primary aerodynamic brake system and of the secondary mechanical brake system.

The aerodynamic brake system includes the three blades of the WEC, each equipped with individual controllers, pitch drives and emergency power supplies. Aerodynamic braking is carried out by adjusting the rotor blades in the feathering position. This is done dynamically with the possibility of using different pitch speeds thus avoiding possible load peaks. Each of the three pitch systems on the rotor blade can also operate independently. In the event of grid loss the pitch systems are supplied via their respective individual emergency power supply.

The brake force of a single blade is enough to bring the WEC into a safe speed range. This leads to an increased safety system.

The mechanical rotor holding brake system is installed at the high-speed shaft as an active system. It is activated if the primary safety system fails partially or totally and stops the rotor in conjunction with the blade adjustment system. It is also used to fix the rotor once the aerodynamic braking system has stopped to secure the rotor during maintenance work.

The braking system is designed for a "fail-safe" function. This means that in case of a malfunction or failure of one component within the braking system, the WEC immediately switches to a safe status.

4.4 Safety Equipment

One set of lift abseiling equipment with accessories for platform rescue is available in each nacelle which can be used to evacuate the WEC in the event of an emergency.

4.5 Lightning Protection

The WEC is equipped with a comprehensive lightning protection and earthing system in accordance with IEC 62305 (2006-01) and IEC 61400-24 Ed.1 (2010-06) which is used to protect the WEC from direct (e.g. lightning strike) or indirect damage. The receptors of the blades, the spinner, the nacelle and the lightning rod receive the lightning and subsequently discharge the lightning current via defined paths to the ground. The electrical as well as electronic components of the WEC are protected against interfering fields and disturbance voltage by overvoltage arresters.

Further information is provided in the document "General Information Lightning Protection, Earthing and potential equalization [MM]".

4.6 Fire Safety

The measures taken to improve fire safety are described in the document entitled "*Fire Safety REpower MD/MM*".

5 Wind Turbine Control

5.1 Control System

The micro-processor based control system *REguard Control B* of the *REpower MM92 CCV* is part of the *REpower SCADA system REguard* and allows the integration of the WEC into the *REpower SCADA system REguard*. The access to the control system *REguard Control B* has to be equipped with the optional *REguard Monitoring*. *REguard Monitoring* allows direct access to the turbine controller *REguard Control* and other *REguard* devices installed at the site, such as *REguard Power Management Unit* or *REguard Meteo Station*. Depending on the user level, the *REguard Monitoring* visualizes current operational as well as historical data which is stored on the turbine controller in the nacelle and at the tower base.

For more information about the *REguard Control System*, please refer to the respective product descriptions of the *REguard SCADA System*.

General Data Control System	
Principle:	micro processor
Remote Control:	<i>REguard Monitoring</i>

Table 13: General Data Control System

5.2 Cut-In / Cut-Out strategy

The Cut-In procedure will be initiated only if all operational systems are ready to operate and the Cut-In wind speed is reached or exceeded for 60 seconds. If the conditions for automatic start are met and the previous cause for a stopping procedure has been taken into account, the rotor shall be accelerated by pitching the blades.

The Cut-Out procedure will be initiated only if the wind speed is above the given Cut-Out wind speed within the 10 minute average. After a Cut-Out due to exceedance of Cut-Out wind speed the WEC restarts when the wind speed is 22 m/s within the 10 minute average. However, to cope with extreme gusts, the WEC shall also start the Cut-Out procedure if the wind speed is higher than 30 m/s within the 30 s average and higher than 35 m/s within 1 s. The stopping procedure will pitch the blades into the feathering position and bring the WEC to a safe stop.

The design parameters for operation are within the following range of 10 minute average wind speeds:

Technical Data Cut-In /Cut-Out Strategy	
Cut-in wind speed:	3.0 m/s
Rated wind speed:	12.5 m/s
Cut-out wind speed:	24.0 m/s

Table 14: Technical Data Cut-In / Cut-Out Strategy

5.3 Measures in case of ice accretion³

As ice accretion on wind turbines, especially on rotor blades, may lead to an increased hazard to the environment, different measures can be taken in order to reduce this hazard caused by ice throw.

5.3.1 Ice Detection

REpower wind turbines are equipped with a redundant and state-of-the-art ice detection system as assessed by TÜV Nord, which enables the turbine operating system to detect ice during operation as well as during stand still. This is realized by the following means:

- Comparison measurement of anemometers
- Analysis of the measured values during turbine operation
- Wind turbine protection by vibration monitoring

These monitoring functions trigger status codes in REpower's turbine control system.

5.3.2 Turbine behaviour in case of ice detection

In case of ice detection the wind turbine automatically shuts down. The restart of the turbine is conducted automatically when icing conditions can be excluded.

If the absence of ice has been reported after a visual on-site inspection, it is also possible to restart the turbine manually under specific conditions.

Shutdown and restarting of the wind turbine are recorded in the operating computer's event protocol and are available for subsequent verification purposes.

The configuration of REpowers measures in case of ice accretion can be adapted turbine specifically in case an *annual wind turbine site assessment* has been carried out and the resultant risk class allows different turbine behaviour.

³ Valid with software release 3.XM 4.0 and MM 3.5

6 Masses and Dimensions

The REpower MM92 CCV is generally designed for relatively easy transport and erection. Therefore, the weights are roughly kept at the same level as the MD-series. The possibility to install the nacelle and the drive train separately allows the use of the same crane equipment as for the MD-series. The values given in chapter 6.1 and 6.2 are for information purposes only and may vary from the actual values.

6.1 Weights

Weights	
Rotor blade:	approx. 8.0 t
Hub complete incl. pitch system:	approx. 17.5 t
Nacelle (excl. rotor):	approx. 71.0 t

Table 15: Weights

6.2 Dimensions

Dimensions Blade	
Length:	approx. 45.2 m
Height:	approx. 5.0 m

Table 16: Dimensions Blade

Dimensions Hub	
Diameter:	approx. 4.5 m
Height:	approx. 3.4 m

Table 17: Dimensions Hub

Dimensions Nacelle	
Length:	approx. 10.3 m
Height (hood demounted):	approx. 3.9 m
Width:	approx. 3.8 m

Table 18: Dimensions Nacelle

Dimensions Drive Train (rotor shaft and gear box)	
Length:	approx. 4.9 m
Height:	approx. 2.4 m
Width:	approx. 3.0 m

Table 19: Dimensions Drive Train

All values in this document are for information purposes and actual values may vary due to specific conditions.